

Instructions for installation,  
use and maintenance

---

## **GAS KITCHENS**

---

**I2FZP**

**I4FZP**

---





## CHARACTERISTICS

Supplied by:

Date:

Customer Service:



FAX

e-mail



## INDEX

<b>1 Diagram</b>	4
<b>2 Features of the appliances</b>	5
<b>3 Technical data</b>	5
<b>4 Installation instructions</b>	6
4.1 Safety rules	6
4.2 Structure, framework and safety devices of the appliances	6
4.2.1 Cooking zone	6
4.3 Assembly	6
4.3.1 Installation premises	6
4.3.2 Statutory regulations and technical requirements	6
4.3.3 Installation	6
4.3.4 Gas connection	6
4.3.5 Equipotential	6
4.4 Preparing for installation	7
<b>5 Operation preparation</b>	7
5.1 Preparation and Start-up	7
5.1.1 Start-up	7
5.1.2 Check of power	7
5.1.3 Checking the input pressure	11
5.1.4 Power check with volumetric method	11
5.1.5 Power check for operation with liquid gas	11
5.1.6 Check of pilot flame	11
5.1.7 Checking the primary air	11
5.1.8 Operation Control	12
5.1.9 Operator training	12
5.1.10 Conversion and adjustment	12
5.1.11 Replacement of burner nozzles	12
5.1.12 Setting reduced capacity power	12
5.1.13 Replacement of pilot nozzle (open flames)	12
5.2 Maintenance	12
5.3 Replacing parts	12
5.3.1 Gas valve (open flames)	12
5.3.2 Thermocouple (open flames)	12
<b>6 Instructions for use</b>	13
6.1 Safety, cleaning and repair rules	13
6.2 Start-up	13
6.2.1 Lighting and disconnecting open flame burner	13
Shutdown	13
6.3 Turning the appliance off in case of breakdown	13
6.3.1 What to do in case of failure or prolonged period of disuse	13
6.4 Appliance care and frequency of maintenance	13
6.5 Recommendations for handling stainless steel industrial kitchens	14
6.5.1 Useful information on stainless steel	14
6.5.2 Warnings and advice for maintenance of stainless steel appliances	14
6.5.3 WEEE Directive	15





# 1 - DIAGRAM

Fig. 1

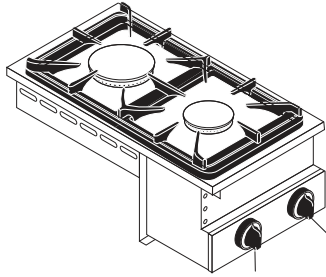

**I2FZP**

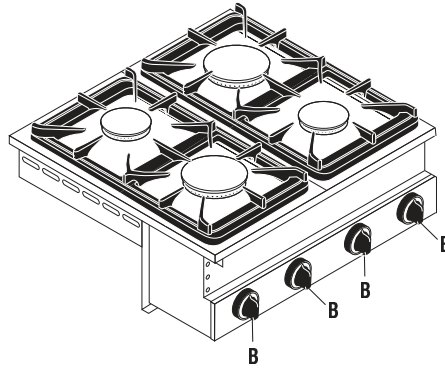

**I4FZP**

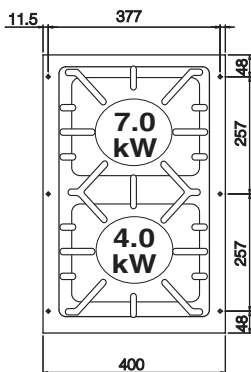
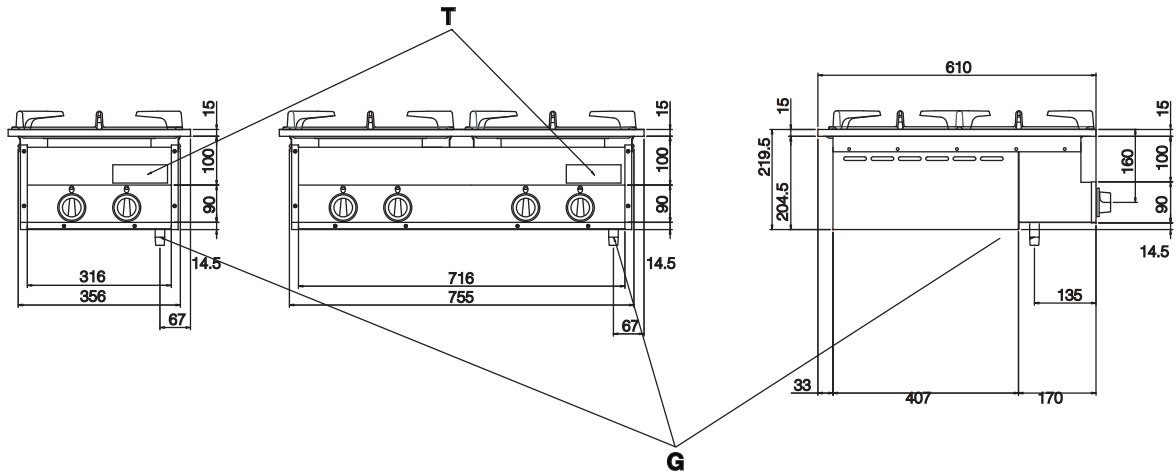

**I2FZP**

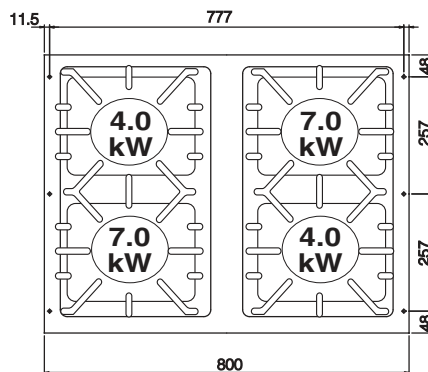

**I4FZP**

- B** Knob
- T** Data plate
- G** Gas connection 1/2"



## 2 - CHARACTERISTICS OF THE APPLIANCES

These appliances are used for professional purposes. Installation, repair and use must be carried out by expert personnel.

These instructions for installation are for our gas kitchens set up for the category in the table on page 5. The data plate is located on the front part of the appliance (on the control panel).

	CAT/KAT	GAS/GAZ	G30	G31	G20	G25	SE <input type="checkbox"/>	FI <input type="checkbox"/>	DK <input type="checkbox"/>	CZ <input type="checkbox"/>	SK <input type="checkbox"/>	SI <input type="checkbox"/>
	I12H3B/P	P mbar	30	30	20	-	IT <input type="checkbox"/>	CH <input type="checkbox"/>	PT <input type="checkbox"/>			
	I12H3+	P mbar	28	37	20	-	ES <input type="checkbox"/>	IE <input type="checkbox"/>	GB <input type="checkbox"/>	GR <input type="checkbox"/>		
	I12H3+	P mbar	28	37	20	-	NL <input type="checkbox"/>					
CE	I12L3B/P	P mbar	30	30	-	25	DE <input type="checkbox"/>					
	I12ELL3B/P	P mbar	50	50	20	20	FR <input type="checkbox"/>	BE <input type="checkbox"/>				
TIPO/TYPE	I12E+3+	P mbar	28	37	20	25	AT <input type="checkbox"/>	CH <input type="checkbox"/>				
MOD.	I12H3B/P	P mbar	50	50	20	-	LU <input type="checkbox"/>					
ART.	I12E	P mbar	-	-	20	-	EE <input type="checkbox"/>	LW <input type="checkbox"/>	LT <input type="checkbox"/>			
CE N.	I12H3B/P	P mbar	30	30	-	-	EE <input type="checkbox"/>	LW <input type="checkbox"/>	LT <input type="checkbox"/>			
N.	I12H3+	P mbar	28	37	20	-	NO <input type="checkbox"/>	MT <input type="checkbox"/>	CY <input type="checkbox"/>	IS <input type="checkbox"/>	HU <input type="checkbox"/>	
Σ Qn kW	I3B/P	P mbar	30	30	-	-	CY <input type="checkbox"/>					
MOD.	I3+	P mbar	28	37	-	-						
Predisposto a gas: - Gas preset: - Prevu pour gaz: - Eingestellt für Gas: - Preparado para gas: - Geschuckt voor:												
VAC	kW		Hz		MADE IN ITALY							
THE APPLIANCE MUST BE CONNECTED IN COMPLIANCE WITH THE LAWS IN FORCE AND INSTALLED IN A WELL-VENTILATED ROOM. READ THE INSTRUCTION MANUALS BEFORE INSTALLING AND USING THE APPLIANCE. THE APPLIANCE MUST BE INSTALLED BY QUALIFIED PERSONNEL.										G30/G31		28/37 mbar
										G20		20 mbar

## 3 - TECHNICAL DATA

Model	Description	Dimensions in mm. (LxPxH)	N. CE
I2FZP	2 burners with pilot flame	400 x 610 x 220	51BS3547
I4FZP	4 burners with pilot flame	800 x 610 x 220	51BS3547

TABLE 1

Model	X Ø 100	Z Ø 120		
Category	I12H3+			
Construction type	A			
Air necessary for combustion	m³/h	8	14	
Nominal thermal power	kW	4.0	7.0	
Minimum thermal power	kW	1.2	2.9	
Overall thermal power (gas)	Hour consumption			
	G20 m³/h	G25 m³/h	G30/G31 kg/h	
I2FZP	11.0 kW	1,16	-	0,86
I4FZP	22.0 kW	2,33	-	1,72
Connection pressure				
Methane gas 2H	G20	20 mbar		
Liquid gas 3+	G30/G31	28/37 mbar		
Gas connection values				
Methane gas 2H	(HuB = 9.45 kWh/m³) in m³/h		0.423	0.825
Liquid gas 3+	(HuB = 12.87 kWh/kg) in kg/h		0.313	0.611
Nozzles Ø 1/100 mm				
Main burner	G20	Nominal thermal power	145	200
		Minimal thermal capacity	Adjustable	Adjustable
	G30/31	Nominal thermal power	100	135
		Minimal thermal capacity	45	75
No. of nozzles, pilot burner				
	G20	27	27	
	G30/G31	19	19	
Primary air distance "A"				
	Methane gas G20	7	15	
	Liquid gas G30/G31	Open	Open	



## 4 - INSTALLATION INSTRUCTIONS

### 4.1 Safety rules

- Installation, modifications and maintenance of the appliance must be carried out by authorised personnel in compliance with current safety standards. The manufacturer declines all responsibility for failure to comply with these obligations.
- Ventilation system installation can be carried out only by expert personnel.
- If the appliance is to be installed near walls, dividing walls, kitchen equipment or decorative panelling, these should be in non-flammable material. If not, all appliances must be coated with thermal-insulation fireproof material. Make sure that all fire prevention standards and safety precautions are strictly adhered to.

### 4.2 Structure, equipment and safety devices of the unit

18/10 chrome-nickel steel outer panelling.

#### 4.2.1 Cooking zone

- Burner with stabilized flame.
- Pilot flame.
- Gas cocks with safety and adjustable from maximum to minimum.
- Thermoelectric ignition safety.
- Enamelled cast-iron pan supports.
- The bodies of the burners, the injector-holder cups and the flame spreaders are made of nickelled cast-iron.
- 18/10 chrome-nickel steel cooking top.
- Knobs in thermosetting material.

### 4.3 Assembly

#### 4.3.1 Installation premises

This is a type A1 appliance. It must be installed in an adequately ventilated room in order to avoid potentially unacceptable concentrations of harmful substances in the space in which the appliance is installed. This room must meet all applicable local and national regulations.

The appliance must be installed in an adequately ventilated room in order to ensure the air flow necessary for combustion, in accordance with all applicable local and national regulations.

The appliance can be installed on its own or with other similar equipment.

If the appliance is to be installed near inflammable walls, a minimum distance of 150 mm around the sides and back should be allowed.

If this distance cannot be obtained, take proper heat-protection action such as fitting tiles or thermal radiation protection material to the walls.

Before connecting the appliance to the gas supply, check on the data plate that the appliance is suitable and type-tested for the type of gas available.

If the type of gas indicated on the data plate of the appliance does not correspond to the gas which is present, refer to the paragraph "Conversion and adaptation".

#### 4.3.2 Statutory regulations and technical requirements

During installation of the appliance, the following regulations must be adhered to:

- Relevant legal directives;
- Local building and combustion regulations;
- "Technical rules for gas systems" worksheet;
- "Technical rules for liquid gas" worksheet;
- "Gas installations in industrial kitchens" worksheet;

- Relative accident prevention standards;
- Local gas utility regulations.
- Local building and fire codes.

#### 4.3.3 Installation

Before installation, gas connection, power check, conversion or adjustment and start up ask for gas supply company advice.

#### 4.3.4 Gas connection

The gas connection may be made with a continuous wall, stainless steel flexible hose with a maximum extension of 1.5 metres, in accordance with all applicable local and national regulations. Hoses must not pass through spaces which might become crammed with items and they must not come into contact with any moving parts such as drawers.

After completing gas connection, check for leaks using a special leak-detector spray.

#### 4.3.6 Equipotential

The appliance must be hooked up to a unipotential system. The required terminal is located near the cord inlet. It is marked by a tag with a symbol .



The manufacturers cannot be held responsible for any damage due to inadequate or incorrect installation or non-compliance with the regulations.



## 4 - INSTALLATION INSTRUCTIONS

### 4.4 Preparing for installation

The gas kitchens type INCASSO must be set on a regular worktable, made of fireproof material and in compliance with the current hygiene and safety standards.

It is of vital importance to observe the following instructions.

Kitchens units can go near other appliances such as a fryer, as long as the required distance of 50 mm (min.) is kept.

In order to install the unit properly on the worktable, proceed as follows:

**A: fig. 2) Base:** With a drill, make an opening in the worktable as described in fig. 2.

The worktable and appliance are clamped with six M5 screws; first drill the relevant holes in the worktable as described in fig. 2. In order to prevent liquids from leaking in between the lining and the appliance, it is necessary to waterproof the leaks with sanitary silicone, anti-mould and heat resistant to at least 100°C (i.e. Pactan 6076). The knob position is fixed; therefore, in the design of the parts where the appliance will be fit into, the relevant panel will have to be provided with a special hole (fig. 1).

**B: fig. 3) Housing:** Make an opening in the worktable in order to fit in the appliance as described in fig. 3 (the rise can be performed perfectly by means of a bent L-shaped metal support). The appliance is clamped to the worktable with six M5 screws fit through holes previously drilled (fig. 3). Fit the appliance and fasten it to the worktable with the screws. Fill the intermediate leak (about 3 mm wide) with heat resistant (at least 100°C) anti-mould silicone (i.e. Pactan 6067) according to the current hygiene standards. The knob position is fixed, hence the furniture structure where the appliance has to be housed will have to be provided with matching holes (fig. 1).

**C: fig. 4) Base with anti-seepage edge:** Make a frame on the stainless steel worktable as described in fig. 4. Fit the appliance and fasten it with the parts supplied with it. The knob position is fixed; hence the worktable structure will have to be provided with matching holes (fig. 1).

In order to prevent overheating of the furniture, it is important to have air circulate inside the space near the machines. If the space under the machine housing is accessible, a closing panel must be put in to prevent accidental contact with hot walls and electric wires. To this end, it is necessary to make holes at the back and possibly at the front as well, for a total of at least 40 cm<sup>2</sup> for the models 400, 80 cm<sup>2</sup> for the models 800 and 120 cm<sup>2</sup> for the models 1200.

This panel must be made of fireproof material and applied at a distance between 50 mm (min.) and 90 mm (max) from the bottom of the machine, further, to ensure internal air circulation must be provided with a hole 40 cm<sup>2</sup> / 80 cm<sup>2</sup> / 120 cm<sup>2</sup>. Preferably at the front (fig. 2/3/4).

Panels and/or inflammable parts must be at a distance of at least 300 mm from the hot walls of the machine.



## 5 - SET-UP FOR OPERATION

### 5.1 Preparation and Start-up

Before starting up the appliance, remove the protective wrapping.

Then carefully clean the working surface and the external parts with lukewarm water and detergent, using a damp rag to remove all traces of anti-rust material applied in the factory, then dry with a clean cloth.

#### 5.1.1 Start-up

Before starting up the appliance, check that its specifications (category and type of gas used) match those of the family and group of the gas available locally.

If not, it is necessary to adapt the appliance to the gas family or group required (see paragraph "Conversion and adjustment").

To start up the appliance, see the instructions for regular use.

#### 5.1.2 Check of power

The appliances must be used with the specific nozzles for the nominal power.

The power may be:

- the nominal power indicated on the data plate of the appliance;
- the reduced capacity power.

These nozzles are shown in table 1 "Technical data".

Nominal power is also obtained in respect of the supply pressure:

- from 15 to 22.5 mbar for gases of the second family (G20/methane)
- from 25 to 45 mbar for gases of the 3rd family (G30/butane, G31/propane)

The appliance shall not be operated outside the above-mentioned pressure ranges.

To adjust power with reduced capacity, use the data in table 1.

If you wish to further check the nominal power, you may do so by using a gas meter according to the so-called "volumetric method".

A simple inspection is usually enough to check if nozzles are functioning correctly.



# CHARACTERISTICS

Fig. 2

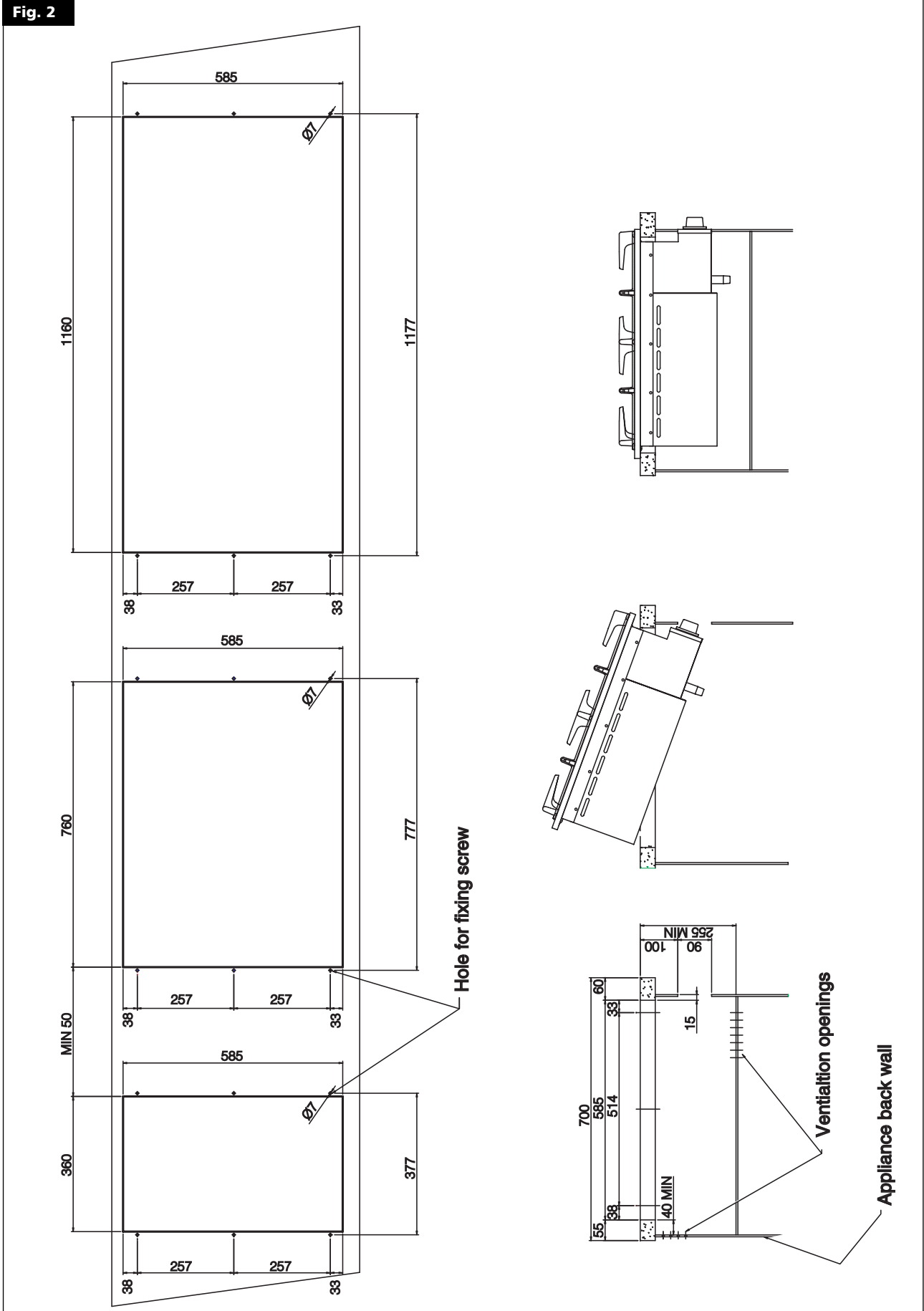





# CHARACTERISTICS

Fig. 3

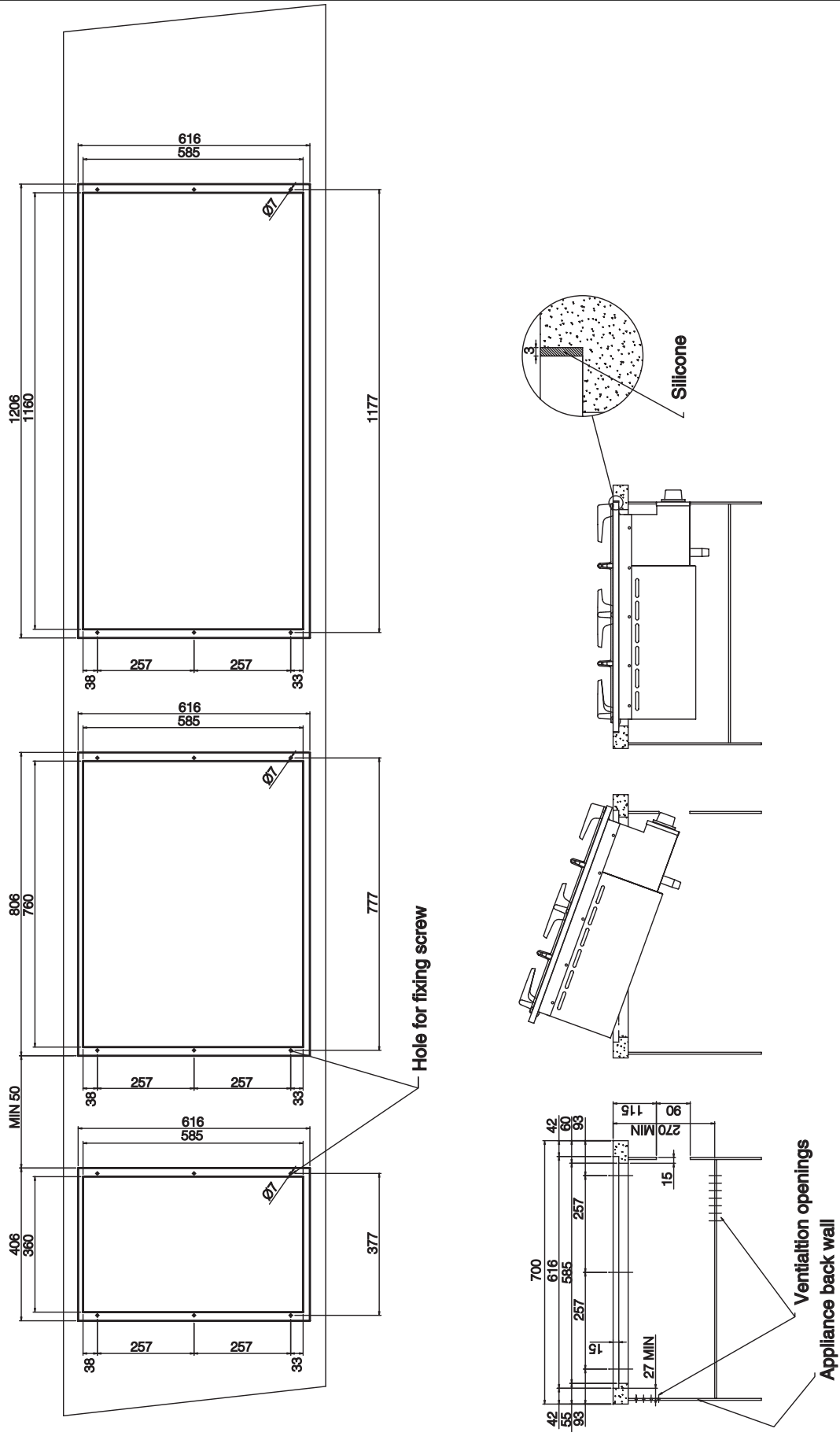



# CHARACTERISTICS

**Fig. 4**

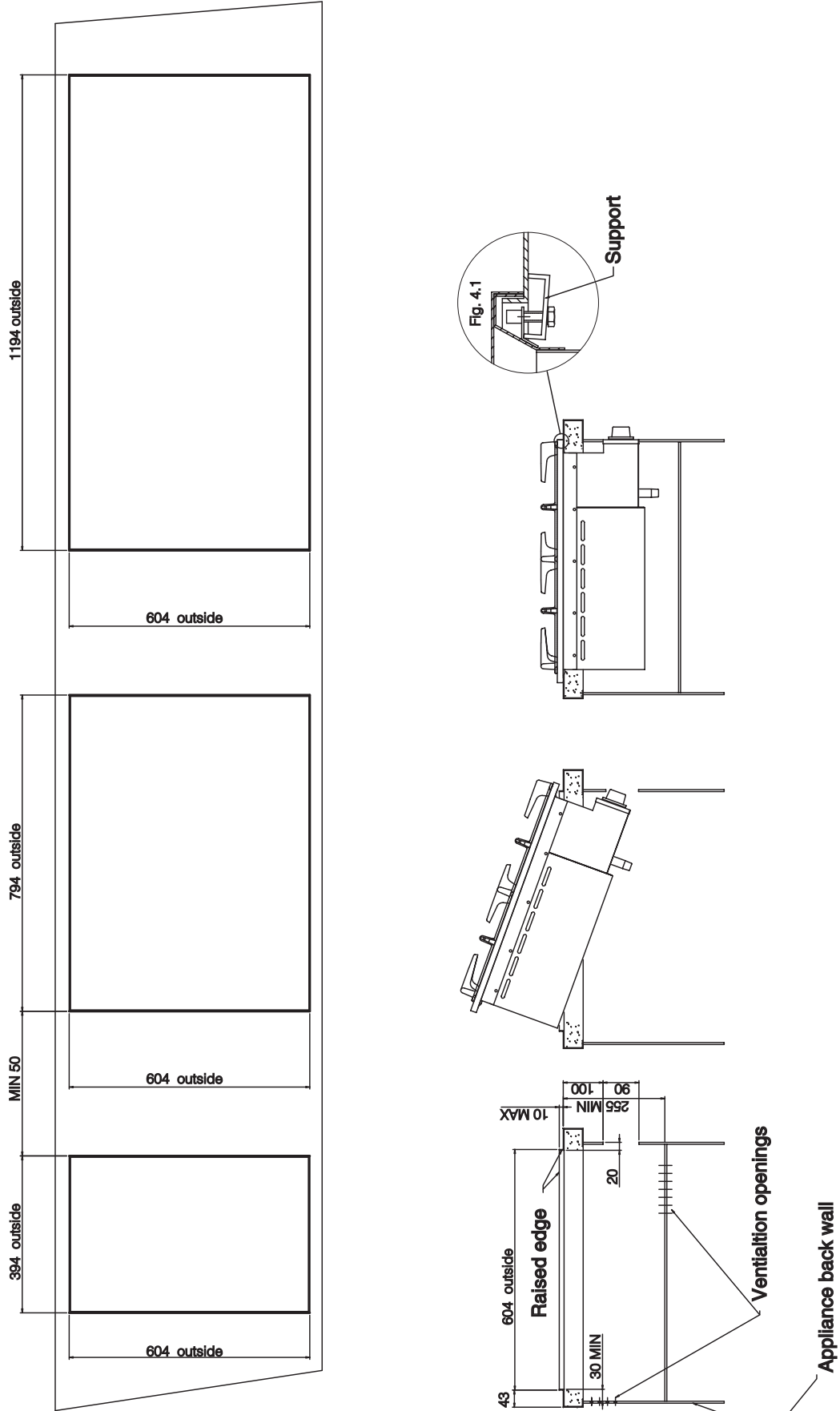



## 5 - SET-UP FOR OPERATION

Fig. 5

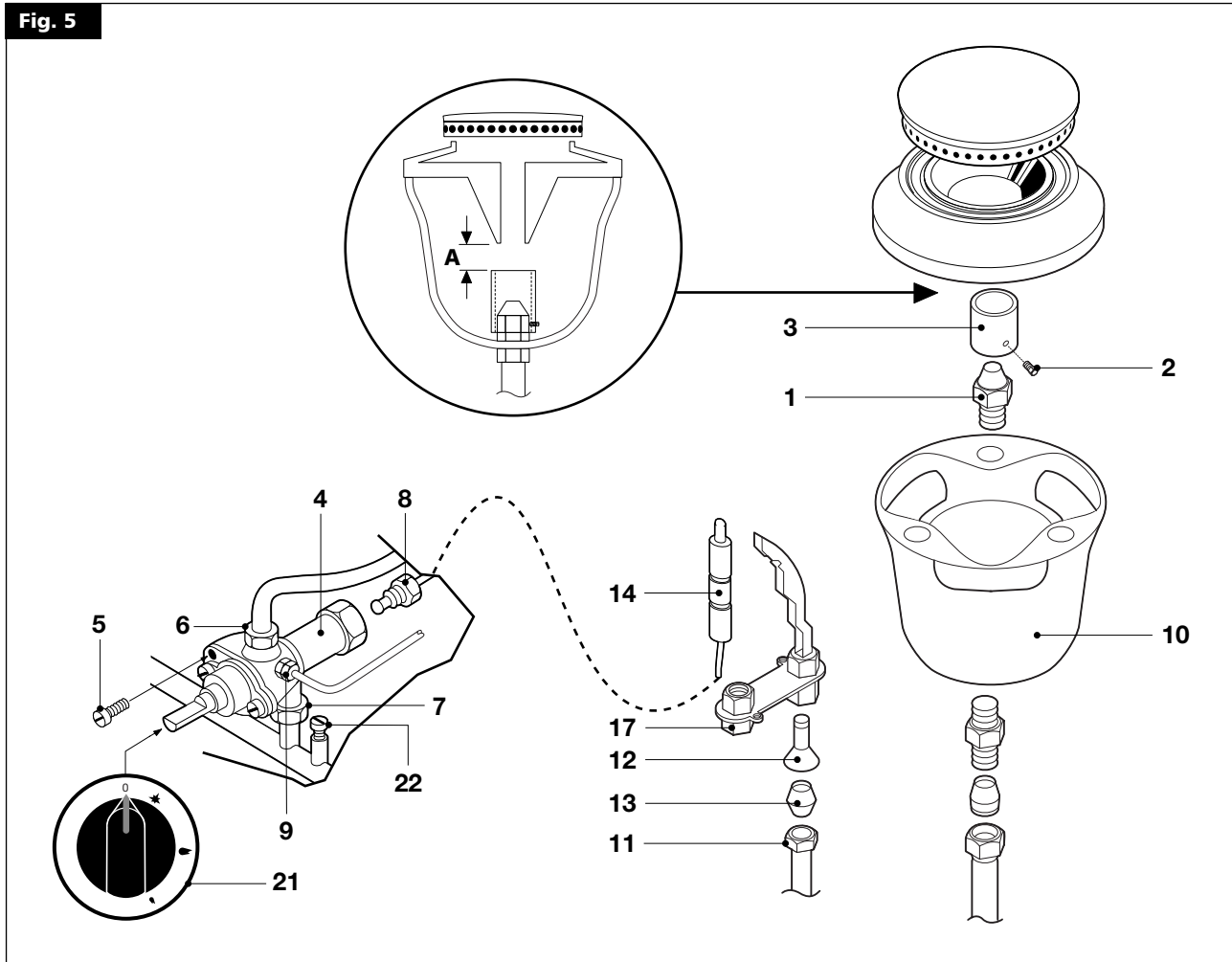

### 5.1.3 Checking the input pressure (fig. 5)

Input pressure should be measured using a fluid measuring gauge (e.g. a gooseneck pipe, min. resolution 0.1 mbar).

Remove lock screw (22) from the pressure intake tube and connect the gauge hose: once measurement is complete, replace the screw (22).

### 5.1.4 Power check with volumetric method

Using a gas meter and a stopwatch, you can read the volume of gas output per time unit. The correct volume corresponds to the value "E" expressed in litres/hour (l/h) or litre/minute (l/min).

The following formula is used to calculate the value of "E":

$$E = \frac{\text{Power}}{\text{Operating calorific value}}$$

It is important measure the power when the appliance is in standby status.

The calorific power value can be requested from the local gas company.

The nominal power and the minimum power with respect to the nominal pressure are obtained by consulting the table for the adjustment of the gas passage (table 1).

### WARNING



There is no pre-adjustment device for the nominal power.

### 5.1.5 Power check for operation with liquid gas

Check if the type of nozzles used meet manufacturer requirements.

Check that the pressure reducer installed in the system has an outlet pressure which is compliant with paragraph 5.1.2 "Check of power" (can be checked on the data plate of the appliance or by measuring the pressure).

### 5.1.6 Check of pilot flame

For proper regulation, the pilot flame must surround the thermocouple and it must have a perfect appearance; otherwise, check injector (table 1) and gas pressure.

### 5.1.7 Checking the primary air

The open flames are equipped with primary air adjustment (table 1).

Air volume flow is correct when there is sufficient protection against the flame rising when the burner is cold or in case of flashback when the burner is hot.



## 5 - SET-UP FOR OPERATION

### 5.1.8 Operation Control

- Start the appliance in accordance with the instructions;
- Check that the appliance does not have any leaks by using a leak-detecting spray.
- Check ignition and that flame on the main burner lights properly and is correctly formed, even on low.
- Check that the pilot flames work properly.
- A servicing and maintenance contract is recommended.

### 5.1.9 Operator training

- Explain and show the user how the machine works according to the instructions, and hand him this manual.
- Remind the user that any structural alterations or any building modification or renovation may affect the combustion air supply, thus requiring a second operation check.

### 5.1.10 Conversion and adjustment

To change over from one kind of gas to another, for example from methane to liquid gas, or to another type of gas, the use of suitable nozzles for the main burner is required, in accordance with the table "TECHNICAL DATA".

The nozzles of the main burners and pilot for different types of gas, marked with the relative diameter in hundredths of mm, are in an envelope which is provided with the appliance. After transformation or adaptation, carry out operating checks as described in paragraph 5.1.8, "Operation control."

### 5.1.11 Replacing burner nozzles (fig. 5)

To replace the nozzle (1): remove the grill, the burner cover, the burner body and the tray of the top.

Then unscrew the screws (2) which fasten the primary air bushing and replace the nozzle (1). See the table "TECHNICAL DATA".

Once the suitable nozzle has been installed, adjust the distance of the primary air and fasten the bushing with the appropriate screw. See the table "TECHNICAL DATA".

### 5.1.12 Setting reduced capacity power (fig. 5)

The minimum setting screw (5) should be adjusted as follows:

- for operation with LPG it should be screwed all the way down;
- for operation with methane, use the gas flow table to check the value in l/min with respect to the operating calorific value (measurement in accordance with the volumetric method). Start the appliance in accordance with the instructions. Turn the knob to the minimum position and use screw (5) to adjust the flow (clockwise = flow reduction; counter-clockwise = flow increase).

### 5.1.13 Replacement of pilot nozzle, open flames (fig. 5)

Remove the grill, the flame separator and the pilot body. Loosen the screw that holds the pilot to the burner and lift it to a more convenient position. Loosen the nut (11) and extract the bicone (13) and the injector (12). Replace the injector. See the table "TECHNICAL DATA" and re-assemble, performing the steps in reverse order.

### 5.2 Maintenance



**Attention! Before doing any repair or maintenance work, unplug the appliance.**

The following maintenance program should be carried out at least once a year:

- Check that all the safety and adjustment devices are working properly;
- Check that the burners are working properly with regard to:
  - ignition
  - combustion safety;

Check functioning of the appliance as described in paragraph "Operation Control";

If it should be necessary to clean the open flame burners, proceed as follows:

- Clean the grills, covers and bodies of the burners;
- Clean the parts with water and detergent and an appropriate tool. Rinse and dry.

When reassembling the parts, make sure you place them back in the right position.

### 5.3 Replacing parts



**All parts must be replaced by authorized technicians only!**

To replace the following parts first remove all the control knobs and control panel (after loosening the fixing screws), then extract the ignition wire.

#### 5.3.1 Open flame gas valve (fig. 5 - pos. 4)

Loosen the fitting of the pipes (6) and (9) of the gas and of the thermocouple (8), loosen the fitting (7) for the fastening of the valve on the ramp and replace the piece.















#### 5.3.2 Open flame thermocouple (fig. 5 - pos. 14)

Loosen the nut (8) for fastening the thermocouple on the valve and on the burner (17) and replace the piece (14).



## 6 - INSTRUCTIONS FOR USE

### 6.1 Safety, cleaning and repair rules

-  • This appliance is used for the preparation of meals at industrial level. Usage and cleaning can be carried only by expert personnel. Maintenance and repair can be carried out only by skilled technical personnel.
-  • These indications must be communicated to all those concerned during internal training.
-  • Attention! This appliance must be constantly watched over when being used!
-  • Grease and overheated oil can catch fire. Use this appliance only under constant control. Never use water to put out grease or oil! Cover with a lid, turn off the hot plate and remove pot from the burner.
-  • Do not leave the burners running.
-  • Do not overload the kitchen. For proper use, pots should not be bigger than the flames.
-  • Parts of the appliance and attachments exposed to food must be cleaned with detergents and rinsed thoroughly with potable water.
-  • Do not clean the appliance using water jets or steam, whether direct or pressurized!
-  • If the room is being cleaned with water/steam jets or high-pressure equipment, it is necessary to switch off the appliance first!
-  • Before starting to clean the appliance, disconnect from the mains.
-  • Do not use inflammable liquid to clean the appliance.
-  • Repairs may be carried out only by skilled personnel.
-  • During repairs, the appliance must undergo voltage omnipolar insulation (local switch, i.e. safety load cut-off switch).
-  • Noise emission values of the appliance in operation are below 70dB (A). This value is compulsory according to certain national safety standards.

#### WARNING

-  **Attention!** The manufacturer declines all responsibility concerning mistakes included in these instructions due to translating or printing errors: the manufacturer also reserves the right to change the product as he sees fit, though without changing its essential features. The manufacturer declines all responsibility for any non-compliance with the provisions contained in this manual.

### 6.2 Start-up

#### 6.2.1 Lighting and shutting off open flame burner (Fig. 1)

Turn the knob of the desired burner (21) to the spark position. Press all the way down and use a match or other suitable instrument to light the pilot burner. Hold the knob down for 15-20 seconds. If, when the knob is released, the pilot light goes out, repeat the operation.

Then place the knob in the maximum or minimum position so that the main burner ignites.

To shut off the burner, turn the knob to the right to the spark position, and the main burner will go out.

To shut off the pilot light, place the knob in position (0).

#### Shutdown

To shut off the main burner, turn the knob to the spark position. Only the pilot flame will remain lit. For complete shutdown, turn the knob to position (0); in this position the pilot burner also goes out.

### 6.3 Turning the appliance off in case of breakdown

In case of breakdown, shut down the appliance as instructed in the paragraph "What to do in case of failure or prolonged period of disuse". In case of breakdown, close the connecting cock of the unit. Disconnect the appliance from the power mains.

#### 6.3.1 What to do in case of failure or prolonged period of disuse

When the appliance is not to be used for a long time, clean thoroughly, close the gas cock and switch off any electric power.

In case of malfunctioning or failure, close the gas cock. In case of malfunction, call the service centre.

### 6.4 Appliance care and frequency of maintenance

-  **Attention! When cleaning, carefully avoid washing the appliance with direct water jets or high-pressure water!**

**Cleaning must be performed when the appliance is cold.**

Thorough daily cleaning of the appliance, after disconnecting it, will keep it in perfect working order and make it last longer. All steel parts should be cleaned with water and a detergent, using a damp cloth; do not use abrasive substances or corroding detergents.

Do not use steel wool, which could cause rust to form.

For the same reason, avoid touching the appliance with anything made of iron. Do not clean with sandpaper and lubricating gel paper.

If absolutely necessary, you may use pumice powder.

If the appliance is extremely dirty, use a synthetic sponge (i.e. Scotchbrite sponge).

After cleaning the appliance, rinse with clean water and wipe with a clean cloth.

If the main burner needs cleaning, proceed as follows:

- Remove the pan support, cover, rings and burner crown;
- Clean burner parts with water, soap and a suitable tool, then rinse and wipe;
- When reassembling the parts, make sure you place them back in the right position.

All maintenance and repair work must be carried out by authorized technicians only.

-  **Never clean the appliance with water jets or high-pressure water!**

The appliance must be checked at least once a year. For this reason, a service agreement contract is recommended.



## 6 - INSTRUCTIONS FOR USE

### 6.5 Recommendations for the treatment of stainless steel industrial kitchens

#### 6.5.1 Useful information on stainless steel

Industrial kitchens are generally made of stainless steel having the following material codes:

- 1.4016 or 1.4511 = magnetizable chromed steels
- 1.4301, 1.4401 and 1.4571 = non-magnetizable chromed steels

Chromed steels have favourable thermo-technical characteristics. In fact, they have less of a tendency to warp due to the effect of heat. Chrome-nickel steels, instead, have good corrosion resistance features.

Stainless steel corrosion resistance is given by an inactive coat that builds up on the surface by coming into contact with oxygen.

The oxygen in the air is already enough to build up the inactive coat that allows automatic removal of anomalies and damage due to mechanical actions. The inactive coat builds up or re-builds up faster if the steel comes in contact with running water containing oxygen.

A more powerful effect is given by oxidative acids (nitric acid, oxalic acid). These acids are used if the steel has undergone strong chemical stresses, hence generally losing its inactive coat.

The inactive layer can be chemically damaged or jeopardized by reducing agents (oxygen consumption) if they come in contact with the steel, concentrated or at high temperatures. These active substances include for instance:

- saline and sulphurous substances
- chlorides (salts)
- concentrated spices such as mustard, vinegar essences, soup cubes, kitchen salt solutions, etc.

More damage can be caused by:

- outside rust (i.e. from other components, tools or incipient rust)
- iron particles (i.e. file dust)
- contact with non-ferrous metals (element build up)
- lack of oxygen (i.e. no air inlet, water lacking oxygen).

#### 6.5.2 Warnings and advice for maintenance of stainless steel appliances

- Stainless steel equipment surfaces must be kept clean and in contact with air at all times. When not running, keep appliance doors open so as to allow air to run through it.
- Regularly remove calcium, grease, starch, and egg white deposits where rust may build up if there is lack of air. Do not use bleaching products or products containing chloride. Follow all indications given by the company concerning special soaps and cleaning methods to be used for the appliance. If no specific cleaning recommendations are available, it is necessary, however, to use detergents having a low chloride content. After cleaning, remove all soap residues with plenty of clean water and thoroughly dry the surfaces.
- Minimize contact of stainless steel with concentrated acids, spices, salts, etc. Even acid vapours coming from cleaning the tiles favour stainless steel corrosion.
- Particularly for pots and multiple appliances, it is not recommended to load the cooking chamber only with food having a high salt content.

It is preferable to cook different food together, i.e. fatty dishes or vegetables containing acids.

- Avoid damaging the stainless steel surface, in particular with different metals. Residues from other metals help build up the formation of chemical microelements that may cause rust. At any rate, it is appropriate to avoid contact between iron and steel since it produces rust. Any contact between stainless steel and iron (steel wool, pipeline chips, chalybeate waters) can start corrosion phenomena.

As for mechanical cleaning, it is recommended to use only steel wool or natural, plastic or steel bristle brushes. Steel wool or brushes with stainless steel can cause rust due to rubbing. Newly

formed rust spots can be removed with slightly abrasive liquid soaps or fine-grained sand paper. Larger rust spots can be removed with 2-3% of hot oxalic acid solution. If these cleaning products do not do the job, a nitric acid (10%) treatment is required.



**Attention! These treatments can be carried out only by expert personnel according to current regulations.**



---

## 6 - INSTRUCTIONS FOR USE

---

### 6.5.3 The 2002/96/EC (WEEE) Directive: information to users

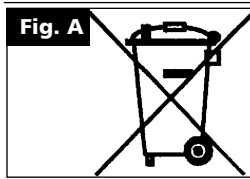

This informational note is meant only for owners of equipment marked with the symbol shown in fig. A on the adhesive label featuring the technical specifications applied on the actual product (the label also giving the serial number).

This symbol indicates that the product is classified, according to the regulations in force, as an item of electrical and electronic equipment and conforms to EU Directive 2002/96/EC (WEEE) meaning that, at the end of its service life, it must be treated separately from domestic waste, i.e. it must be handed in free of charge to a separate waste electrical and electronic equipment collection centre or returned to the reseller when buying a new equivalent item of equipment.

The user is responsible for delivering the unit at the end of its life to the appropriate collection facilities. Failure to do so shall result in the user being subject to the penalties prescribed by the legislation in force on waste.

Suitable separated collection so that the unit no longer used can be sent off for environmentally compatible recycling, treatment and disposal helps avoid possible negative effects on the environment and on health and facilitates the recycling of the product's component materials.

For more detailed information on available collection systems, contact the local waste disposal service or the shop you purchased the unit from.

Producers and importers fulfil their responsibility for environmentally compatible recycling, treatment and disposal both directly and by joining a collective scheme.

---

### NOTES

**WARNING**  
THE MANUFACTURER CANNOT BE HELD RESPONSIBLE  
FOR ANY INACCURACIES IN THIS BOOKLET DUE  
TO COPYING OR PRINTING ERRORS.  
DUE TO ITS POLICY OF CONTINUAL PRODUCT IMPROVEMENT,  
THE MANUFACTURER RESERVES THE RIGHT  
TO MAKE ANY CHANGES DEEMED NECESSARY.  
**THE MANUFACTURER CANNOT BE HELD RESPONSIBLE  
IF THE INSTRUCTIONS CONTAINED IN THIS MANUAL  
ARE NOT OBSERVED.**



**GIGA GRANDI CUCINE** S.r.l. - Via Pisana, 336 - Loc. Olmo - 50018 SCANDICCI (FI) - ITALY -  
Tel. +39 055 722 33 (11 linee r.a.) - Fax +39 055 7310 056 - [www.gigagrandicucine.it](http://www.gigagrandicucine.it) -  
[info@gigagrandidicucine.it](mailto:info@gigagrandidicucine.it)